

MULTI SCREEN®

Double Trommel Screens



The Zemmler Concept of Screening



MADE IN GERMANY

The Zemmler Siebanlagen GmbH is a manufacturer of mobile and stationary double trommel screening machines. The company was founded in 2000. Within a few years a flourishing company has grown from a one-man business. In cooperation with our customers and partners, we have constantly expanded and optimized our product and service portfolio. Innovative, flexible and customized - that is our motto. This allows us to always offer solutions that are precisely tailored to our customers requirements.

The Zemmler screening machines are completely produced in our very own factory. In addition to the sale and rental of new and used screening machines, we also offer a repair and 24-hour spare parts service to our customers.

Our MULTI SCREEN® screening machines are used in the most diverse areas. Thanks to the proven double trommel technology, a wide variety of materials can easily be screened. This technology enables screening into three fractions in one single operation. Replaceable wire screen coverings ensure perfect adaptation to individual screening requirements.



ZEMMLER SIEBANLAGEN GMBH

Established and committed manufacturer mobile and stationary screening plants



PRODUCED IN THE LAUSITZ. SOLD TO THE WORLD.

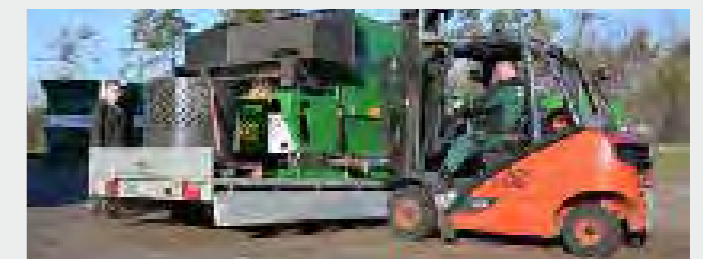
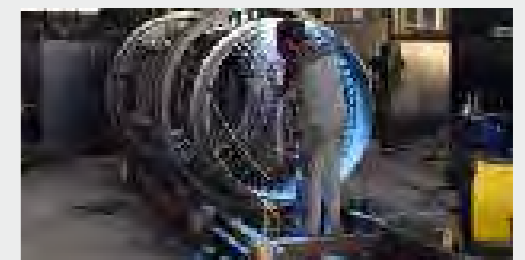
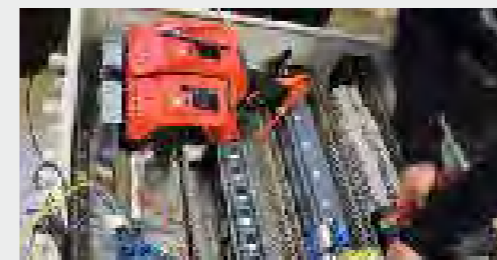
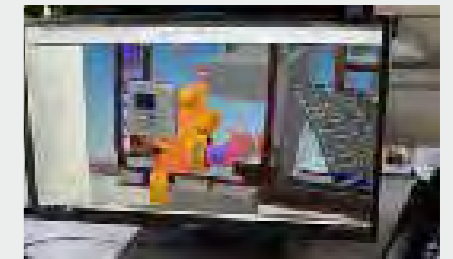

SCREENING IN 3 FRACTIONS: THE DOUBLE-DRUM TECHNOLOGY



Figure: patented conical drum for increased throughput and optimal flow rate of fresh wood, alternative fuels and wood recycling.

The technology of the double drum enables the screening of 3 fractions in one step.

Wire screens, which are mounted around the inner and outer drum, ensure a sharp separation cut and clean screening of the individual fractions (fine, middle and coarse fractions).

FINE FRACTION

2 - 80 mm, as desired

MIDDLE FRACTION

between 2 - 80 mm and up to 170 mm

COARSE FRACTION

bigger than 170 mm (Standard)

THE ZEMMLER CONCEPT OF SCREENING.



ZEMMLER® MULTI SCREEN®

AREAS OF APPLICATION:

GLASS

COAL

SAND AND GRAVEL

WOOD CHIPS

SHREDDED OLD WOOD

COMPOST

SLAGS

RECYCLING

TOPSOIL

ALTERNATIVE FUELS

CONSTRUCTION WASTE

CRUSHED STONE

SPLIT

WOOD

ETC...

Our MULTI SCREEN® screening machines are used in the most diverse areas. Due to the proven double-drum technology, a wide variety of materials can be screened without any problems.

The exchangeable wire screen coverings allow an optimal adaptation to the individual screening requirements.



FEATURES



OUR DOUBLE TROMMEL

With our double drum 3 fractions are possible in one operation. This saves on workload, personnel costs and even additional machines. The massive construction of the inner drum protects the outer screens from coarse material.



CLEANING BRUSH

A cleaning brush with its own drive ensures a clean outer screen.



CAT-ENGINES

Ensuring reliable drive high-quality CAT motor In diesel-hydraulic systems already according to EU stage V.



CORROSION PROTECTION

The frames of our conveyor belts are completely hot-dip galvanized. All Painting is done in high quality 2K polyurethane one-coat top coat. In this way we can provide long-term corrosion protection.



WIRE SCREEN COVERINGS

By using wire screen coverings you remain flexible. Choose from different mesh sizes, wire strengths and shapes. The screens can be easily exchanged without special tools or even a drum change.

In addition, the purchase costs are about 90 percent lower than for a complete drum unit. Small dimensions and a relatively low weight enable an easy transport.



MAINTENANCE-FRIENDLY

Wide opening drum and maintenance doors provide convenient access for inspection, care and maintenance work.

CONTROL SYSTEM

Large touch display with graphic information and an optional remote control enable the simple and intuitive operation of our screening machines.



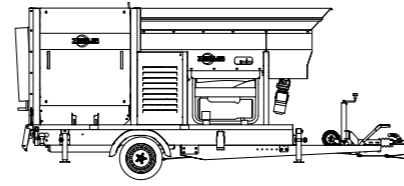

THE SMALLEST

- ✓ up to 20 m³/h for small gardening and landscaping businesses
- ✓ single drum, lightweight construction (1.8 t)
- ✓ can be towed by common cars

MULTI SCREEN PORTFOLIO

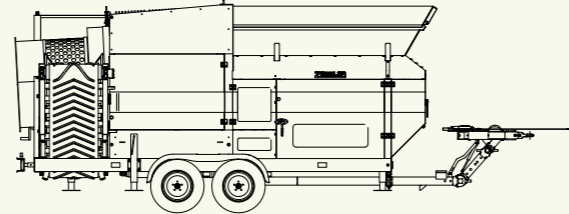

THE LITTLE ONE

- ✓ up to 30 m³/h for middle gardening and landscaping companies
- ✓ double drum for up to 3 fractions, compact and low weight (3.5 t)
- ✓ can be towed by SUV's, vans and small trucks

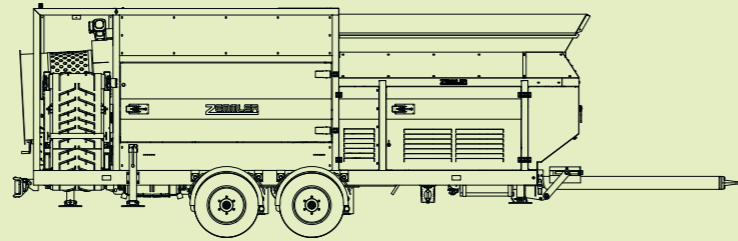

THE COMPACT ONE

- ✓ up to 60 m³/h for professional gardening and landscaping
- ✓ based on the MS 1600 with larger screening trommel for more capacity

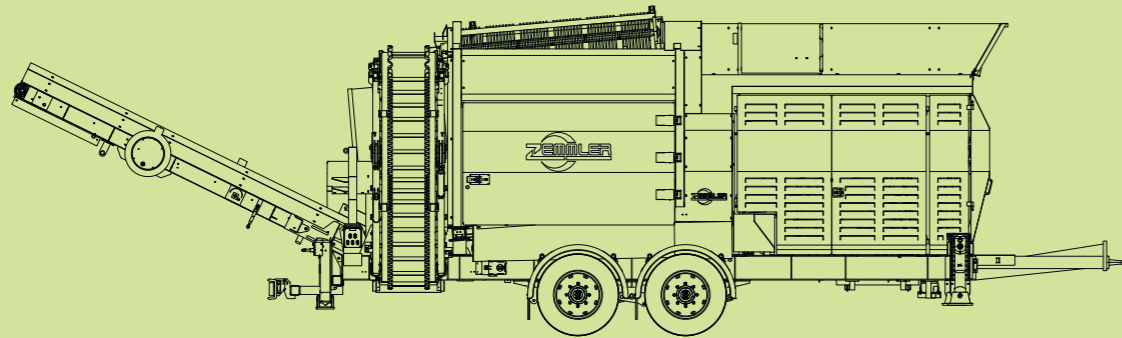

THE ALLROUNDER

- ✓ up to 120 m³/h for professional use on medium and large sized businesses for a wide range of applications
- ✓ the mobile, hydraulically driven double trommel screening machine impresses with high flexibility in use, economy and performance

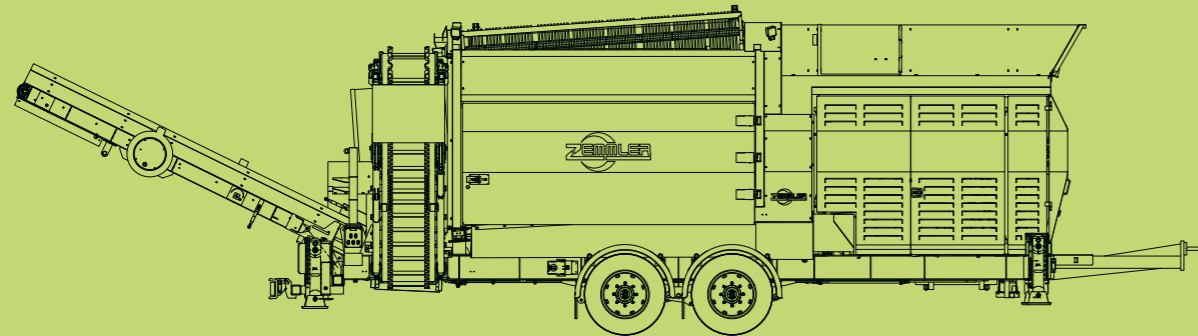

THE BIG ONE

- ✓ up to 150 m³/h for all large plants with a high throughput and screening quality in different areas
- ✓ the length of the double trommel and the wire screen coverings allow clean separation with small meshes and cohesive material

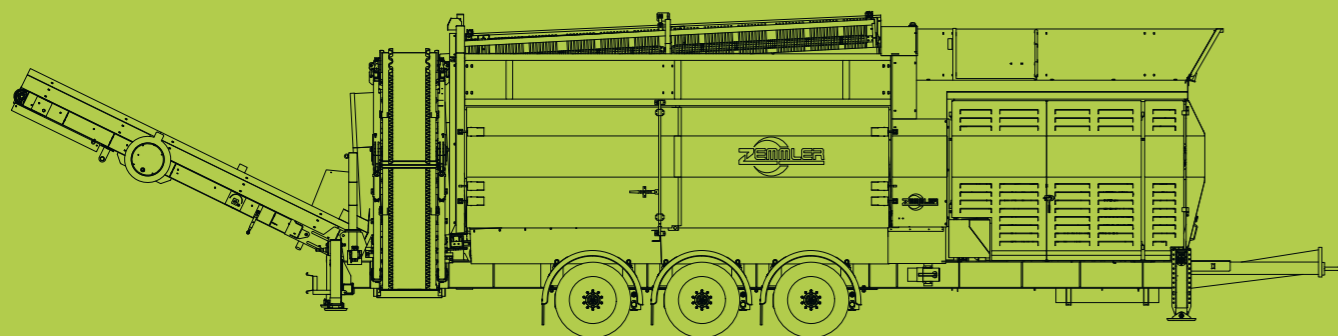

THE HIGHLY PROFESSIONAL ONE

- ✓ up to 180 m³/h for users with very large throughputs and small mesh sizes obtain optimum screening results
- ✓ it combines size and double trommel technology, opening up new dimensions in processing

MS 1000

MS 1600

MS 3200

MS 4200

MS 5200

MS 6700

MULTI SCREEN® MS 1000

The ZEMMLER® MULTI SCREEN® MS 1000 is a powerful professional machine. Due to its lightweight construction, with a weight of 1.8t, it can be transported by many common cars to the respective place of use.

The MS 1000 is equipped with a single drum, but the proven system of the interchangeable wire screen covering remains in place, so that two clean fractions can be separated.

1,8 t
total weight



up to 20 m³/h
throughput

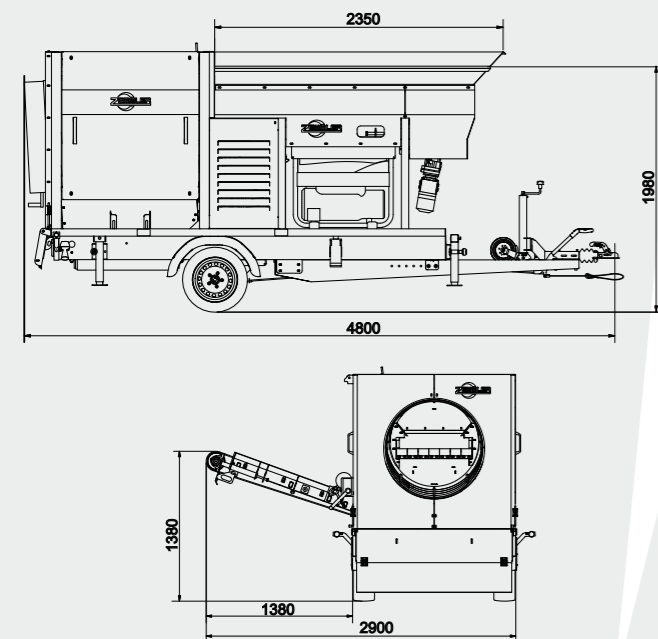

Drum length	Single drum, 1,500 mm
Drum diameter	900 mm
Mesh sizes	2 bis 80 mm
Screening surface	approx. 3 m ²
Weight	max. 1,800 kg
Drive	electric drive (16A), optional power generator
Hitch	trailer hitch ball, drawbar eye Ø 40/50 mm

MULTI SCREEN® MS 1600-S

The ZEMMLER® MULTI SCREEN® MS 1600 STARTER was developed especially for small users such as garden and landscaping contractors, civil engineering companies or small municipalities as an alternative to the mobile MS 1600. The low weight and the compact design, suitable for trailers up to 2.5 t are designed to facilitate transport and use on various construction sites.

With the help of an extension ring, the machine can be converted from a twofraction to a three-fraction screening machine within few minutes.



up to 30 m³/h
throughput

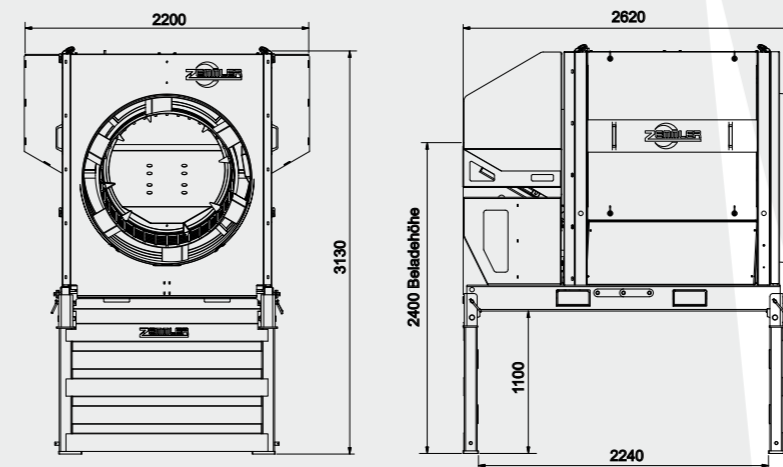

Drum length	1,750/2,640 mm
Drum diameter	1,300 mm
Mesh sizes	2 to 80 mm
Screening surface	approx. 11 m ²
Weight	approx. 2,000 kg
Drive	electric drive (16A) optional power generator
Feed chute	approx. 1 m ³ capacity, width 2,200 mm

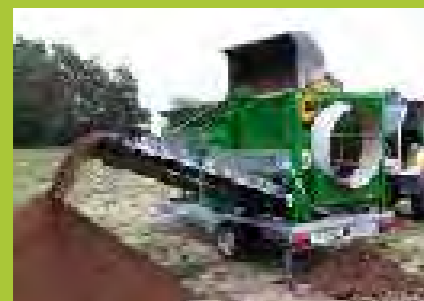

2 FRACTIONS

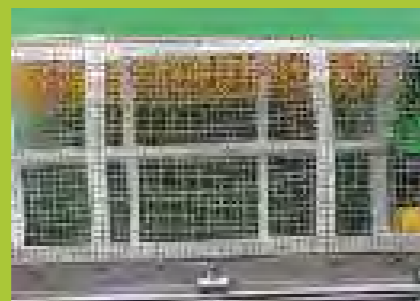

SINGLE DRUM WITH WIRE SCREEN COVERING



CAR-TRAILER



2 OR 3 FRACTIONS



OPTIONAL EXTENSION RING

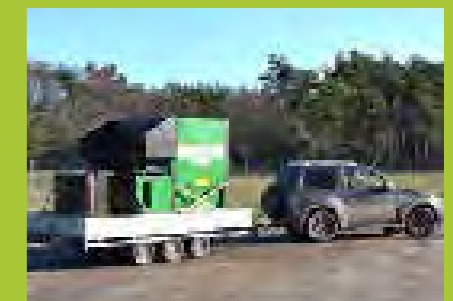

EASY TRANSPORT

MULTI SCREEN® MS 1600

The ZEMMLER® MULTI SCREEN® MS 1600 is mainly conceived for gardening and landscaping. The compact dimensions and the low weight of 3.5 allow the transport by small vans and small trucks.

By using an extension ring, the machine can be converted from a two-fraction to a three-fraction screening machine within few minutes. Three fractions in one step - just like the big ones

up to 30 m³/h
throughput



3,5 t
total weight

MULTI SCREEN® MS 3200

The ZEMMLER® MULTI SCREEN® MS 3200 is a compact machine for small businesses, municipalities and the landscaping. The construction is similar to the MS 1600, but the screening drum is clearly longer. With a loading height of just under 2,500 mm and a feed width of 3000 mm, feeding with the excavators and wheel loaders commonly used in landscaping is possible without any problems. With the help of an extension ring, the MS 3200 can be converted from two to three fractions screening machine in few minutes.

up to 60 m³/h
throughput

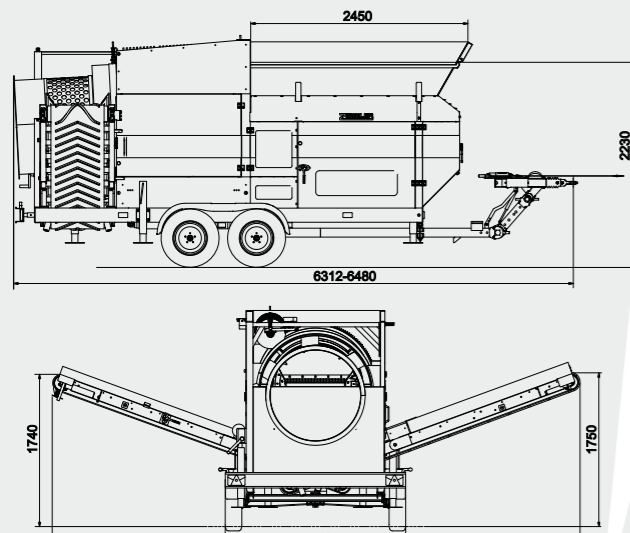

Drum length	1,750/2,640 mm
Drum diameter	1.300 mm
Mesh sizes	2 bis 80 mm
Screening surface	approx. 11 m ²
Weight	max. 3,500 kg optional as 5t-version
Drive	electric drive (16 A), optional power generator
Hitch	trailer hitch ball, drawbar eye Ø 40/50 mm

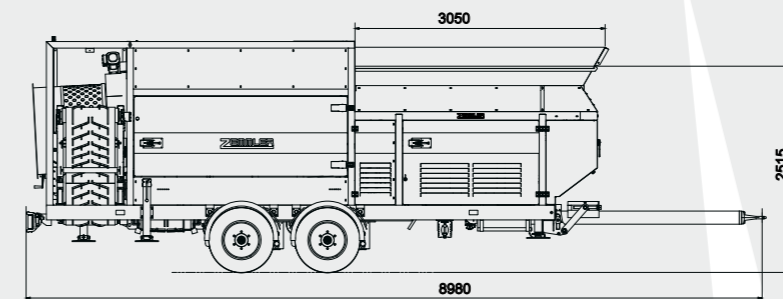

Drum length	3,000/3,900 mm
Drum diameter	1,300 mm
Mesh sizes	2 bis 80 mm
Screening surface	approx. 18 m ²
Weight	approx. 7,500 kg
Drive	electric drive (32 A), optional power generator
Hitch	drawbar eye Ø 40/50 mm

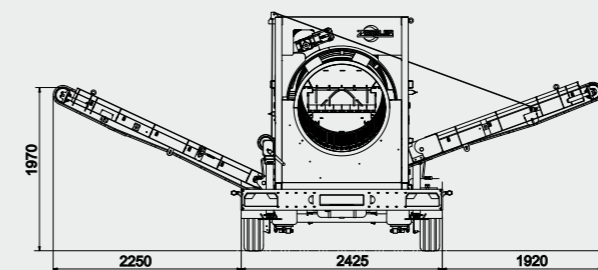

2 OR 3 FRAKTIONS

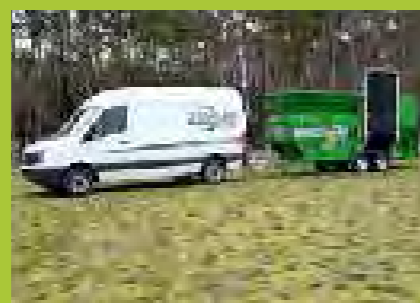

EASY TRANSPORT



SKID OR HOOKLIFT



2 OR 3 FRACTIONS



EXTENDED FEEDER



SKID OR HOOKLIFT

MULTI SCREEN® MS4200

The ZEMMLER® MULTI SCREEN® MS4200 was designed for the use on medium and large plants for a wide range of applications. The mobile, hydraulically driven double-drum screening machine convinces by high flexibility in use, options, efficiency and performance. Maintenance work is due to the good accessibility of the motor unit as well as the large side doors can be done quickly and easily.



up to 120 m³/h
throughput

MULTI SCREEN® MS5200

The ZEMMLER® MULTI SCREEN® MS 5200 is an extremely convincing solution for all large plants with high throughput. The length of the double drum and the wire screen linings enable a sharp, clean separation.

The proven diesel-hydraulic drive is intuitively operated via a touch-screen. As an option, extended conveyor belts are mounted, which provide more flexibility for the material discharge.



up to 150 m³/h
throughput

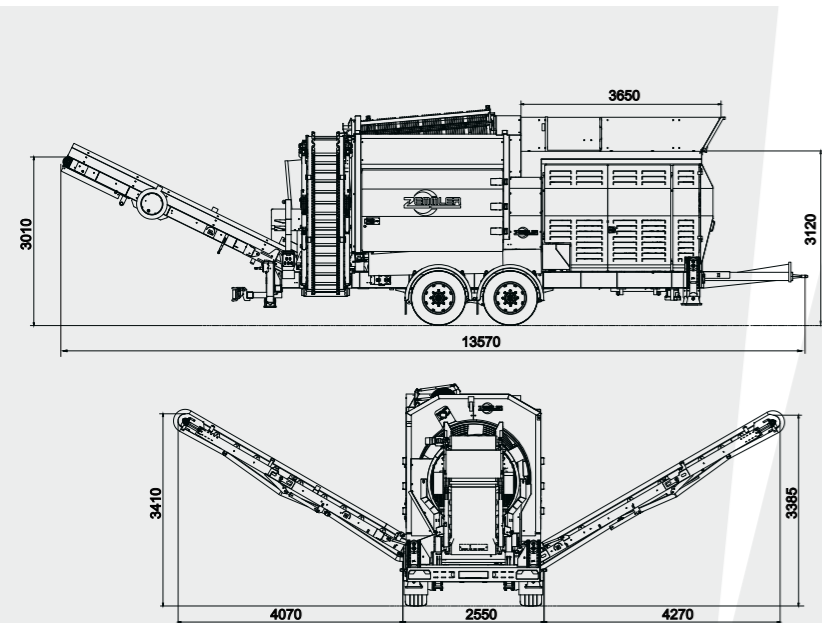

Drum length	4,200 mm
Drum diameter	2,000 mm
Mesh sizes	2 bis 80 mm
Screening surface	approx. 31 m ²
Weight	13,500 kg (Standard)
Drive	diesel-hydraulic, optional (diesel-) electric
Hitch	drawbar eye Ø 40/50 mm

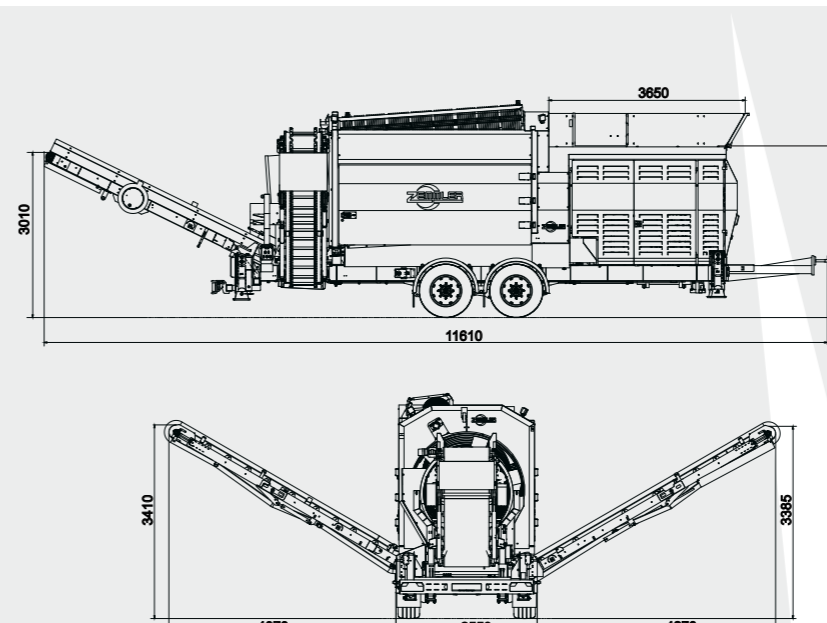

Drum length	5,200 mm
Drum diameter	2,000 mm
Mesh sizes	2 bis 80 mm
Screening surface	approx. 46 m ²
Weight	approx. 14,500 kg (Standard)
Drive	diesel-hydraulic, optional (diesel-) electric
Hitch	drawbar eye Ø 50 mm



3 FRACTIONS



STONEGRID

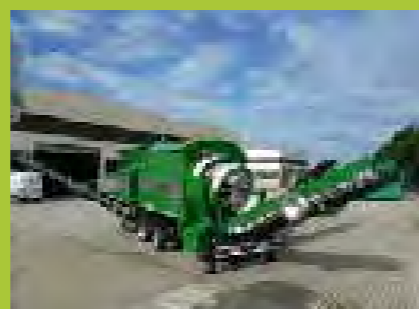

EXTENDED CONVEYORS

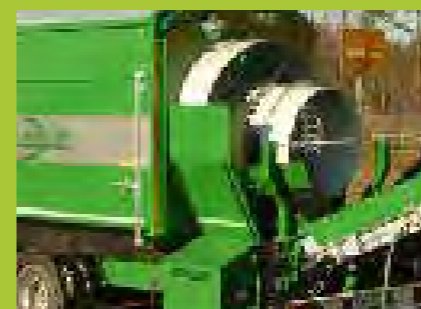

CONICAL TROMMEL



CRAWLER CHASSIS



SKID MOUNTED

MULTI SCREEN® MS6700

The ZEMMLER® MULTI SCREEN® MS 6700 is the largest mobile screening machine in our portfolio. In it, size and double drum technology is combined, to open up new dimensions in reprocessing. With its total screening surface of more than 60 m² and a drum length of 6.70 m, it achieves maximum output of up to 180 m³/h. Especially users with a very high throughput and small mesh size obtain optimum screening results.



up to 180 m³/h
throughput

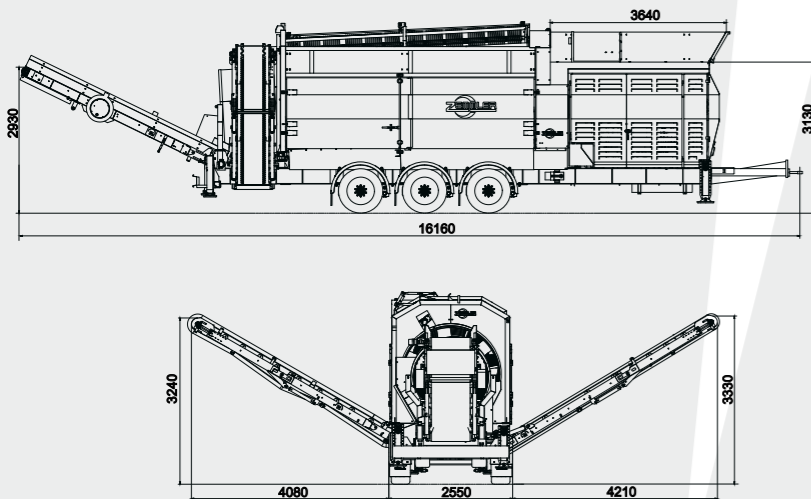

Drum length	6,700 mm
Drum diameter	2,000 mm
Mesh sizes	2 bis 80 mm
Screening surface	approx. 63 m ²
Weight	18,000 kg
Drive	diesel-hydraulic, optional (diesel-) electric
Hitch	drawbar eye Ø 50 mm



EXTENDED CONVEYORS



SKID MOUNTED



CRAWLER CHASSIS

OR PREFERABLY STATIONARY?



MULTI SCREEN® MS3200-ST

Throughput:	up to 60 m ³ /h
Trommel:	3,000/ Ø1,300 mm
Drive:	electric



MULTI SCREEN® MS4200-ST

Throughput:	up to 120 m ³ /h
Trommel:	4,200/ Ø2,000 mm
Drive:	electric



MULTI SCREEN® MS5200-ST

Throughput:	up to 150 m ³ /h
Trommel:	5,200/ Ø2,000 mm
Drive:	electric



MULTI SCREEN® MS6700-ST

Throughput:	up to 180 m ³ /h
Trommel:	6,700/ Ø2,000 mm
Drive:	electric

The illustrations contain options that are subject to a surcharge.
All specifications are subject to technical changes and further developments.

SCREENING IN 3 FRACTIONS - AND IN COUNTLESS VARIATIONS

Would you like a little more? We have the right options for all your needs and requirements. Choose your special equipment! Here is a small selection:



REMODELLING TO HOOK LIFT
(MS 1600 & MS 3200)



HYDRAULIC STONE GRID



EXTENDED BELTS



EXTENDED RING
FOR 3RD FRACTION



ON WHEELS



ON CRAWLER
CHASSIS



LED-HEADLIGHTS



DRUM MAGNET WITH CHUTE



CHUTE FOR
3RD FRACTION



REMOTE CONTROL



REMODELLING
TO SKID

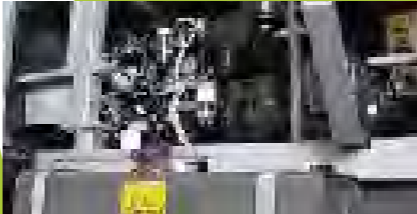

DRIVE: ELECTRIC,
DIESEL-ELECTRIC,
DIESEL-HYDRAULIC



EASY TRANSPORT OF MODULES
(MS 6700 STATIONARY)

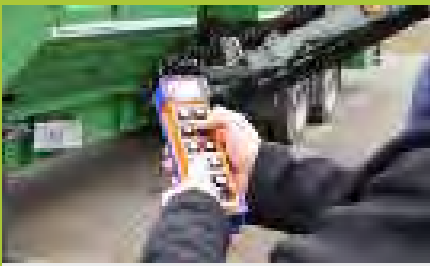

REMOTE CONTROL
MAXI



VARIABLE SCREEN
COVERING
(INSIDE & OUTSIDE DRUM)



VARIOUS DRUM DESIGNS



WEATHER OR DUST
PROTECTION ROOF



SPECIAL LACQUERING



HYDRAULIC
SUPPORT FEET

AND MUCH MORE...

THERE'S SIEVING EVERYWHERE...

A few examples:



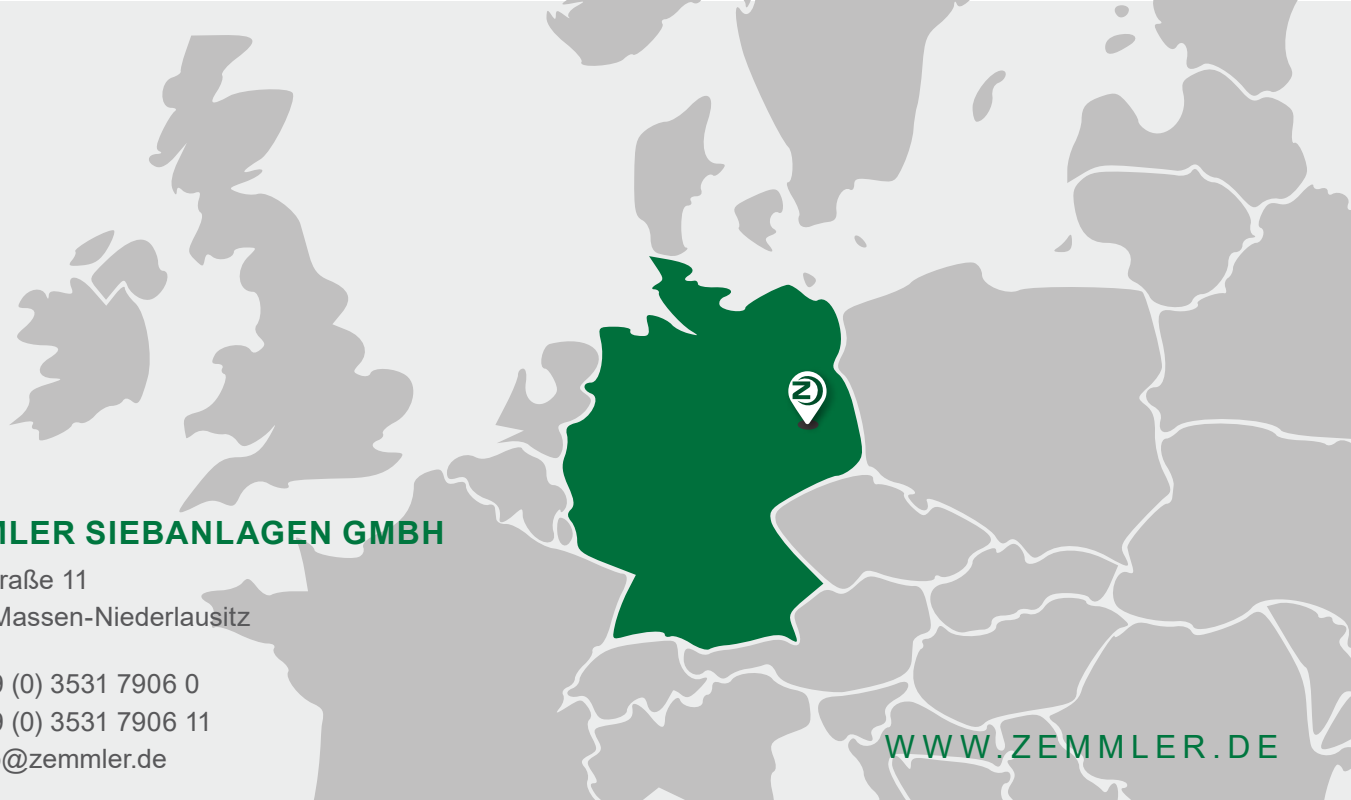

ZEMMLER SIEBANLAGEN GMBH

Nobelstraße 11
03238 Massen-Niederlausitz

- ☎ +49 (0) 3531 7906 0
- ☎ +49 (0) 3531 7906 11
- ✉ info@zemmler.de

WWW.ZEMMLER.DE



RENTALS

Not only can you buy the double trommel screening machines from our own production, you can of course also rent them.



USED MACHINES

We sell used machines from our rental fleet and also used screening machines from other manufacturers.



REPAIR SERVICE

Our mobile repair service and our field service are always at our customers' side, with guaranteed fast response times.

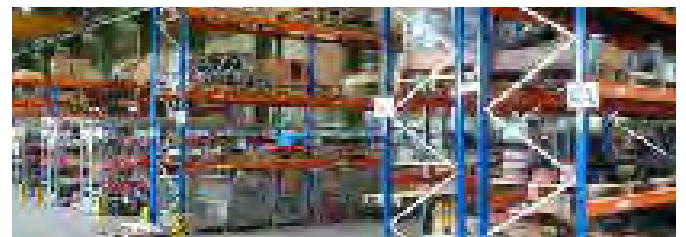

SPARE PARTS SERVICE

Not only for our ZEMMLER® MULTI SCREEN® screening machines, but also for manufacturers such as Ellegaard, SVEDALA and Vedbysonder.